

Hydraulic Features		
Flow range	15-40	l/min
Max. working Press.	350	bar
Ports	P - A - B	G.3/8"
Cartridge & manifold material	Zinc. plated steel	

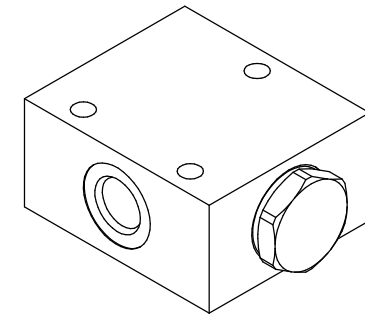

Tutte le quote sono da considerarsi solamente di riferimento.  
All dimensions to be considered reference only.

00	29/03/2023	Prima emissione. (MT2163)	C.Tameni	
REV.	DATA REV.	DESCRIZIONE REVISIONE / REVISION DESCRIPTION	FIRMA / SIGN.	
CODICE / CODE: V1034		OGGETTO / OBJECT: DFL a cartuccia 15-40 l/min	TAGLIA / SIZE:	TIPO / TYPE:
COMMENTI / COMMENTS: Progetto 003-23			FOGLIO / SHEET: 1 di 1	SCALA / SCALE: 1:1,25
DATA / DATE: 29/03/2023	DISEGNATORE / DESIGNER: C.Tameni	CONTROLLATORE / INSPECTOR: R.Valenta	FIRMA CONTROLLATORE / SIGNATURE INSPECTOR:	
MATERIALE / MATERIAL: -	PESO / WEIGHT: -	TOLL. GEN.: ±0,1	SMUSSI / BEVELS: 0,2x45°	RAGGI / RADIUS: 0,2
TRATTAMENTO / TREATMENT: -				
PROF. TRATT. / DEPTH TREAT.: -	DUREZZA / HARDNESS: -			
RUGOSITA' / ROUGHNESS Rq (µ):				
( )				



**OLEODINAMICA MARCHESINI S.P.A.**  
Via Industriale 36  
25080 Prevalle (BS) - Italia

La ditta si riserva ogni diritto di proprietà del disegno  
The company reserves all rights of ownership of the design