

Hydraulic Features		
Flow range	7-20	l/min
Max. working Press.	350	bar
Ports	P - A - B	G.3/8"
Cartridge & manifold material	Zinc. plated steel	

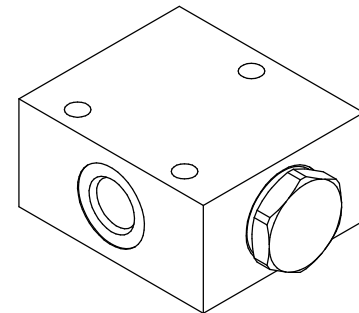

Tutte le quote sono da considerarsi solamente di riferimento.  
All dimensions to be considered reference only.

01	12/06/2023	Added missing dimensions. (MT2320)		C. Cepillo
REV.	DATA REV.	DESCRIZIONE REVISIONE / REVISION DESCRIPTION		FIRMA / SIGN.
CODICE / CODE:		OGGETTO / OBJECT:		TAGLIA / SIZE:
V1033		DFL a cartuccia 7-20 l/min		TIPO / TYPE:
COMMENTI / COMMENTS:				FOGLIO / SHEET:
Progetto 003-23				1 di 1
DATA / DATE:		DISEGNATORE / DESIGNER:		SCALA / SCALE:
29/03/2023		C.Tameni		1:1,25
MATERIALE / MATERIAL:		PESO / WEIGHT:		TOLL. GEN.:
-		-		±0,1
TRATTAMENTO / TREATMENT:		SMUSSI / BEVELS:		RAGGI / RADIUS:
-		0,2x45°		0,2
PROF. TRAT. / DEPTH TREAT.:		DUREZZA / HARDNESS:		
-		-		
RUGOSITA' / ROUGHNESS Rq (μ):				



**OLEODINAMICA MARCHESINI S.P.A.**  
Via Industriale 36  
25080 Prevalle (BS) - Italia

La ditta si riserva ogni diritto di proprietà del disegno  
The company reserves all rights of ownership of the design